

LOADER SPECIFICATIONS

L-1850

100,000 lbs (45,360 kgs) 33 yd³ (25.23 m³)
Standard Operating Capacity



LeTourneau, Inc.

Note: Optional equipment shown in photo.



POWER MODULE

DIESEL POWER OPTIONS

DETROIT DIESEL ENGINE

Model	D4000 16V, DDEC
Type	4-Cycle Turbocharged/Aftercooled
Rated Power	2000 HP (1492 kW) @ 1900 RPM
Cylinders	Sixteen (16)
Bore And Stroke	6.5 in. X 7.5 in. (165 mm X 190 mm)
Displacement	3967 cu in. (65 liters)

CUMMINS DIESEL ENGINE

Model	QSK 60
Type	4-Cycle Turbocharged/Aftercooled
Rated Power	2000 HP (1492 kW) @ 1900 RPM
Cylinders	Sixteen (16)
Bore And Stroke	6.3 in. X 7.5 in. (160 mm X 190 mm)
Displacement	3672 cu in. (60.2 liters)

RADIATOR/OIL COOLER MODULE

Model	Replaceable Tube Type, Side By Side Split Flow
Type	Thermostatically Controlled, Independent, Hydraulic, Motor-Driven, Radiator-Mounted Fan
Fan Speeds	Variable
Cooling Capacity	110 gals (416 l)

AIR FILTRATION

LeTourneau Self-Cleaning KLENZ™ System
99.9% Efficiency Filtered Down to 0.3 Microns
Supply Filtered Air For:

Engine Air
Drive System Cooling
Pressurized Cab

EXHAUST SYSTEM

Low Restriction Mufflers With Top, Rear Hood Discharge



CONTROL SYSTEM-LINC5™

LeTourneau Integrated Network Control System- LINC5™

Microprocessor Based Full Digital Control and Monitoring
• Hydraulics • Electrics • Engine • Traction Drive
Modular Design
Built-in Diagnostics • Dash Display and Keypad
Solid State AC-DC Phase Controlled Traction Drive
No Contactors or Power Switch Gear
Infinitely Variable Speed Control



PROPULSION SYSTEM

Batteries	Four (4) 12-Volt
Model	8D
Starter(s)	Two (2) Delco-Remy 50 MT Type 400
Alternator	220 Amp with Integral Voltage Regulator

A.C. GENERATOR

Model	LeTourneau 12B Generator
Type	Alternating-Current, 3-Phase, 4-Pole
Excitation	Solid State
Feature	Standby Power Capability

TRACTION MOTORS

Model	LeTourneau J2 Traction Motor
Type	Direct-Current, 4-Pole, Shunt-Wound,
Number	Four (4)

DRIVE GEARING

Model	LeTourneau 57
-------	---------------

In-line gear train mounted within the rim of the tire, transmitting power from the traction motor to the tire/rim assembly.

Each drive unit consists of a planetary gear train, hub structure, spindle structure, primary gearbox, and a bearing carrier assembly.

Total Reduction	99:1
-----------------	------

DRIVE SYSTEM COOLING AIR

Function	Filtered Inlet Air Cools Control Box, A.C. Generator And Traction Motors
Blower	Backward Inclined Blade Fan
Drive	Hydraulic Motor



TIRES

STANDARD

Front And Rear Tires	Firestone® 58/85-57 84 PR (L-4) Nylon-Nylon
Rims	47 x 57 w/ 6" Flanges
Front And Rear Tires	Michelin® 60/80-R57 2 Star
Rims	47 x 57 w/ 5" Flanges



TRAVEL SPEED

INFINITELY VARIABLE

Forward And Reverse	0-10.5 mph (0-16.9 Kph)
---------------------	-------------------------



OPERATING CAPACITIES, WEIGHTS AND DIMENSIONS

	STANDARD		HIGH LIFT	
Bucket Capacity	33 yd ³	(25.23 m ³)	31 yd ³	(23.70 m ³)
Operating Payload	100,000 lbs	(45,360 kgs)	94,000 lbs	(42,638 kgs)
Bucket Width	21 ft 0 in.	(6.40 m)	21 ft 0 in.	(6.40 m)
Bucket Width With Deflectors	22 ft 0 in.	(6.71 m)	22 ft 0 in.	(6.71 m)
Hinge-Pin Height	30 ft 4 in.	(9.25 m)	32 ft 2 in.	(9.80 m)
Dump Clearance 45° Discharge	22 ft 4 in.	(6.81 m)	24 ft 2 in.	(7.35 m)
Reach @ Full Lift 45° Discharge	9 ft 8 in.	(2.94 m)	9 ft 8 in.	(2.92 m)
Digging Depth	0 ft 6 in.	(0.15 m)	0 ft 8 in.	(0.24 m)
Height - Bucket Fully Raised	39 ft 9 in.	(12.12 m)	41 ft 2 in.	(12.54 m)
Ground Clearance	2 ft 6 in.	(0.76 m)	2 ft 6 in.	(0.76 m)
Overall Length Bucket Down	58 ft 6 in.	(17.83 m)	60 ft 0 in.	(18.29 m)
Overall Length Carry Position	56 ft 10 in.	(17.32 m)	58 ft 2 in.	(17.73 m)
Wheelbase	23 ft 0 in.	(7.01 m)	23 ft 0 in.	(7.01 m)
Tread	15 ft 0 in.	(4.57 m)	15 ft 0 in.	(4.57 m)
Width Outside Tires	19 ft 10 in.	(6.04 m)	19 ft 10 in.	(6.04 m)
Height Over Cab	20 ft 11 in.	(6.68 m)	20 ft 11 in.	(6.68 m)
Static Tipping Loads:				
Straight	225,000 lbs	(102,060 kgs)	215,000 lbs	(97,524 kgs)
Full 42° Turn	200,000 lbs	(90,720 kgs)	190,000 lbs	(86,184 kgs)
Breakout Force	276,181 lbs	(125,276 kgs)	280,672 lbs	(127,313 kgs)
Operating Weight	506,000 lbs	(229,522 kgs)	511,000 lbs	(231,790 kgs)



STANDARD CONFIGURATION

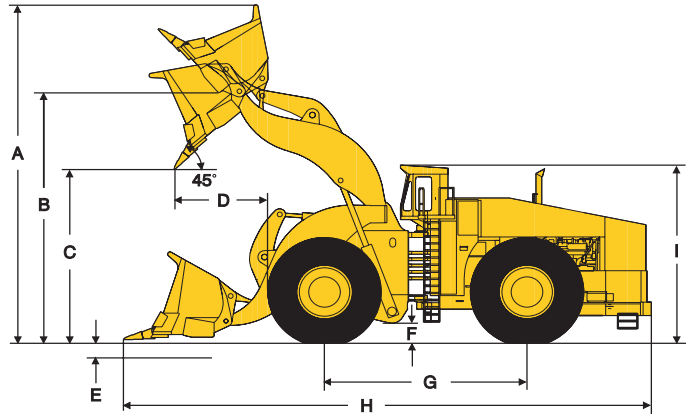
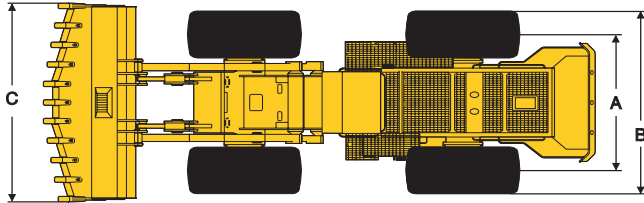

Top View

(A)	15 ft 0 in.	(4.57 m)
(B)	19 ft 10 in.	(6.04 m)
(C)	21 ft 0 in.	(6.40 m)

Side View

	STANDARD		HIGH LIFT	
	Bucket 33 yd ³	(25.23 m ³)	Bucket 31 yd ³	(23.70 m ³)
(A)	39 ft 9 in.	(12.12 m)	41 ft 2 in.	(12.54 m)
(B)	30 ft 4 in.	(9.25 m)	32 ft 2 in.	(9.8 m)
(C)	22 ft 4 in.	(6.81 m)	24 ft 2 in.	(7.35 m)
(D)	9 ft 8 in.	(2.94 m)	9 ft 8 in.	(2.92 m)
(E)	0 ft 6 in.	(0.15 m)	0 ft 8 in.	(0.24 m)
(F)	2 ft 6 in.	(0.79 m)	2 ft 6 in.	(0.79 m)
(G)	23 ft 0 in.	(7.01 m)	23 ft 0 in.	(7.01 m)
(H)	58 ft 6 in.	(17.83 m)	60 ft 0 in.	(18.29 m)
(I)	20 ft 11 in.	(6.68 m)	20 ft 11 in.	(6.68 m)

All dimensions calculated with teeth on bucket.



ELECTRICAL AND MECHANICAL BRAKING

PRIMARY BRAKING SYSTEM

Electric Braking (Regenerative/Retarding) is designed as the primary braking system which can be controlled from either the accelerator or retard/brake pedals. This solid-state, non-wearing parts braking system will bring the loader to a full stop without application of the air-operated disc brakes used for backup.

EMERGENCY AND PARKING BRAKE SYSTEM

Armature speed disc brakes, spring-actuated air release, automatic actuation on all four wheels in the event of pressure loss.



FRAME

The unique LeTourneau box structure frames are fabricated from high-strength, low-alloy steel with excellent weldability and low temperature properties throughout. The front axle is an integral, fixed part of the frame. The rear axle is allowed to oscillate a total of +/- 11 degrees on the rear frame.

The independent power module mounting system is cradled within the rear frame by a three-point isolation system.



INDEPENDENT STEERING AND HOIST SYSTEMS

ARTICULATED POWER STEERING

Joystick controlled articulation - full-time hydrostatic power steering. Constant engine RPM provides full steering response regardless of vehicle speed.

Operating Pressure	3400 PSI	(23,443 kPa)
Articulation Angle	42° Each Side	
Turning Radius		
Standard Lift	43 ft 0 in.	(13.11 m)
High Lift	44 ft 1 in.	(13.44 m)

HOIST & BUCKET CONTROL

Both hoist and bucket control functions are incorporated into a single joystick control. Hydraulic metered, pilot-controlled hoist system is independent of the steering system utilizing single stage, double-acting cylinders mounted outside of the front frame.

Standard/High Lift Cycle Times:

Hoist	14 Seconds
Dump	4 Seconds
Float	6 Seconds
Total Time	24 Seconds



HYDRAULIC SYSTEM

PUMP DRIVE BOX

LeTourneau, Inc. Gearbox
Wet Spline Design with Pressurized And Filtered Lubrication

Ratio 1:1

PUMPS

Main	Piston (4)	500 GPM	(1893 l/min)
Steering	Piston	90 GPM	(341 l/min)
Fan Drive	Piston	45 GPM	(170 l/min)
Blower	Vane	45 GPM	(170 l/min)
Accessory	Piston	14 GPM	(53 l/min)
Cooling System			
Circulating	Vane	110 GPM	(416 l/min)

VALVES

Main	Three (3)	175 GPM	(663 l/min)
	Relief Pressure	3300 PSI	(22,754 kPa)
Steering	One (1)	80 GPM	(303 l/min)
	Relief Pressure	3400 PSI	(23,443 kPa)

CYLINDERS

Double-Acting, Single-Stage

Hoist	Diameter And Stroke (Standard And High Lift)	15 in. X 83 in. (381 mm X 2108 mm)
Bucket	Diameter And Stroke (Standard And High Lift)	12.5 in. X 42.8 in. (318 mm X 1086 mm)
Steering	Diameter And Stroke	7.5 in. X 30 in. (190 mm X 762 mm)

FILTERS

Full System	Return-Flow	10 Micron Absolute
Drivers		10 Micron Absolute
Gearbox		10 Micron Absolute
Piston Pump (Case Drain)		10 Micron Absolute



GENERAL SERVICE DATA

FLUID CAPACITIES

Fuel Tank	1050 gals	(3,975 l)
Hydraulic Tank	375 gals	(1,419 l)
Cooling System	110 gals	(416 l)
Crankcase (Includes Filters)		
Cummins	54 gals	(204 l)
Detroit Diesel	66 gals	(250 l)
Gearbox	7 gals	(27 l)
Drivers (Each)	25 gals	(95 l)



OPERATOR ENVIRONMENT

CAB

Spacious, ergonomically designed operator's cab features a low interior sound level and is mounted directly over the center articulation point, providing excellent visibility. Joystick controlled steering comes standard along with the unique LeTourneau single joystick boom and bucket controls. Climate control vents are strategically located throughout the cab. The joystick operator's seat has adjustable air suspension along with retractable seat belts.



STANDARD FEATURES

STANDARD GAUGES AND INDICATORS

Engine Coolant Temperature Gauge
 Engine Lube-Oil Pressure Gauge
 Fuel Level Gauge
 Hour Meter
 Speedometer
 System Air Pressure Gauge

STANDARD INDICATOR LIGHTS AND AUDIBLE ALARMS

The operator is informed of a potential problem by an audible alarm and text messages on a computer display. The digital display also provides repair technicians with operational data and fault messages in the event of a mechanical, electrical or electronic malfunction.

Three warning lights immediately advise the operator of the severity/condition of various engine, hydraulic, electrical and electronic systems of the loader (RED, AMBER and BLUE).

STANDARD EQUIPMENT

Access Ladder Light Kit
 Air Clean Out Hose in Cab
 Air Conditioning, Filtered And Pressurized
 Air Dryer System
 Air Horn
 Air Tank Bleed Kit
 Automatic Adjustable Lift Height Cut Off
 Automatic Bucket Leveling Device
 Automatic Cabinet Lights
 Automatic Lubrication System
 Backup Alarm, Audible
 Battery Disconnect Switch
 Cigar/Cigarette Lighter
 Door Interlock on Electrical Cabinet
 Drawbar
 Emergency Exit - Removable Safety Window
 Emergency Stop - Cab and Remote Mounted
 Engine Compartment Lights
 Five (5) Gallon Windshield Washer Reservoir
 FOPS, Falling Object Protection System
 Ground Fault Electrics
 Heater-Defroster, High-Output
 HID Headlights
 High, Low Idle Switch
 Idle Timer
 Illuminated Instrument Panel
 Interior Lights
 Joy Stick Hoist And Bucket Controls
 Joy Stick Steering
 Ladder Walkway-Rear Access With Retracting Ladder
 LINCSTM - LeTourneau Integrated Network Control System
 Manual Fire Extinguisher, 21 lbs (9.53 kgs)
 Maintenance Lock-Out Switch
 Mirror, Rearview (Parabolic) (2)
 LINCSTM Alarms
 Parking Brake
 Rear Tow Hitch
 Rock Deflectors (Bucket)
 ROPS, Rollover Protective Structure
 Retractable Seat Belt
 Standby Power Capability
 Sun Visor
 Tinted Safety Glass Throughout
 Turn Signals
 Twelve (12) Volt Power Supply (Cab)
 Wet Windshield Wipers, Front & Rear
 Work Lights, 110 Volt - 500 Watt (4) Front, (2) Rear



OPTIONAL FEATURES

Auxiliary Cab Heater, Water
 Auxiliary Oil Cooler
 Auxiliary Steering System
 Central Service with Fast Fuel
 Engine Heating System, Oil and Water
 Fast Fuel
 Fluid Sampling Kit
 Grease Reservoir Heater
 Hydraulic Tank and Battery Heater
 Jump Start Kit
 Manual Fire Detection and Suppression System
 Remote Monitoring System
 Standby Power



BUCKET HARDWARE OPTIONS

Teeth And Lip Options Available
 Lip Wear Protection
 Skid Plates - Replaceable
 Wear Liner Kits

For additional bucket sizes and hardware options consult your LeTourneau, Inc. dealer representative.



SAFETY CERTIFICATION

Meets the following MSHA, SAE and ISO Safety Standards:

Brake Performance Test SAE J1473 / ISO 3450
 Capacity Rating - Loader Bucket SAE J742
 Exterior Sound Level SAE J88
 FOPS SAE J231 / ISO 3449
 Interior Sound Level SAE J919
 Rated Operating Load for Loaders SAE J818
 ROPS SAE J1040 / ISO 3471
 Steering Test SAE J1511 / ISO 5010

Please Note: Standard/Optional Equipment, Features and Performance conform to U.S. and International Codes as Required.

LeTourneau, Inc. has made every effort to make these specifications as accurate as possible at the time of printing. However, we reserve the right to make changes and improvements at any time without notice, in equipment, materials and specifications. To ensure the most current information, please contact your LeTourneau, Inc. dealer representative.



BUCKETS

STANDARD, SAE-RATED CAPACITY: 100,000 LBS (45,360 KGS)

	Rock	Rock	Rock	Rock	Coal
BUCKET SIZE	28 cy (21.40 cm)	31 cy (23.70 cm)	33 cy* (25.23 cm)	35 cy (26.76 cm)	55 cy (42.05 cm)
MAX HEIGHT	23 ft 1 in. (7.02 m)	22 ft 5 in. (6.84 m)	22 ft 4 in. (6.81 m)	21 ft 11 in. (6.69 m)	23 ft 3 in. (7.07 m)
MAX REACH	8 ft 11 in. (2.72 m)	9 ft 6 in. (2.89 m)	9 ft 8 in. (2.95 m)	10 ft 0 in. (3.05 m)	9 ft 2 in. (2.80 m)
BREAKOUT FORCE	308,739 lbs (140,044 kgs)	280,672 lbs (127,313 kgs)	276,181 lbs (125,276 kgs)	271,690 lbs (123,243 kgs)	224,800 lbs (101,973 kgs)

HIGH LIFT, SAE-RATED CAPACITY: 94,000 LBS (42,638 KGS)

	Rock	Rock	Rock	Rock	Coal
BUCKET SIZE	26 cy (19.87 cm)	28 cy (21.40 cm)	31 cy* (23.70 cm)	33 cy (25.23 cm)	55 cy (42.05 cm)
MAX HEIGHT	25 ft 1 in. (7.64 m)	24 ft 10 in. (7.57 m)	24 ft 3 in. (7.38 m)	24 ft 2 in. (7.36 m)	24 ft 11 in. (7.60 m)
MAX REACH	8 ft 10 in. (2.69 m)	9 ft 2 in. (2.80 m)	9 ft 8 in. (2.95 m)	9 ft 11 in. (3.03 m)	9 ft 5 in. (2.87 m)
BREAKOUT FORCE	326,900 lbs (148,282 kgs)	308,739 lbs (140,044 kgs)	280,672 lbs (127,313 kgs)	276,181 lbs (125,276 kgs)	224,800 lbs (101,973 kgs)

*Standard Bucket Configuration



LeTourneau, Inc.

P.O. Box 2307 • Longview, TX 75606 • (903) 236-6598 • FAX (903) 236-6585
 www.letourneau-inc.com